

SECTION A-A

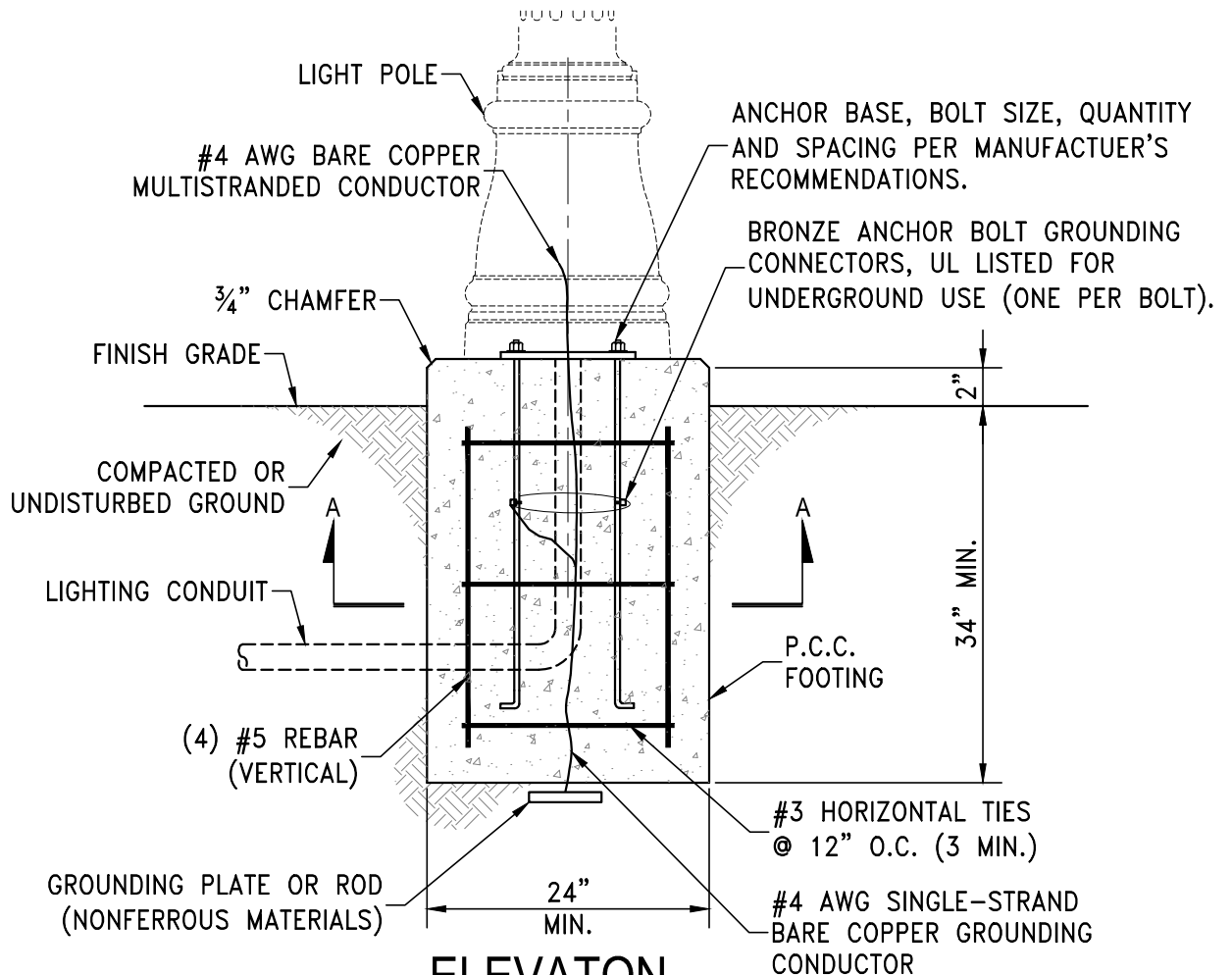

ELEVATION

NOTES:

1. PORTLAND CEMENT CONCRETE (P.C.C.) SHALL BE 4000 PSI MIN. COMPRESSIVE STRENGTH AT 28 DAYS. ALL CEMENT CONCRETE SHALL HAVE A COARSE AGGREGATE GRADATION CONFORMING TO SIZE No. 67. POLYPROPYLENE OR CELLULOSE FIBERS SHALL BE ADDED TO THE P.C.C. AT 1.5 LBS PER CUBIC YARD. MIX DESIGN SHALL CONFORM TO THE REQUIREMENTS OF SECTION 337.10 OF SSPWC. ALL MATERIALS SHALL CONFORM TO SSPWC.



STANDARD DETAILS FOR PUBLIC WORKS CONSTRUCTION

DRAWING No.

LIGHT POLE FOOTING

R-413K

APPROVED BY:KK

DATE: 1/2023