

ACCESS TO SD INLETS 24" DIA. & LARGER

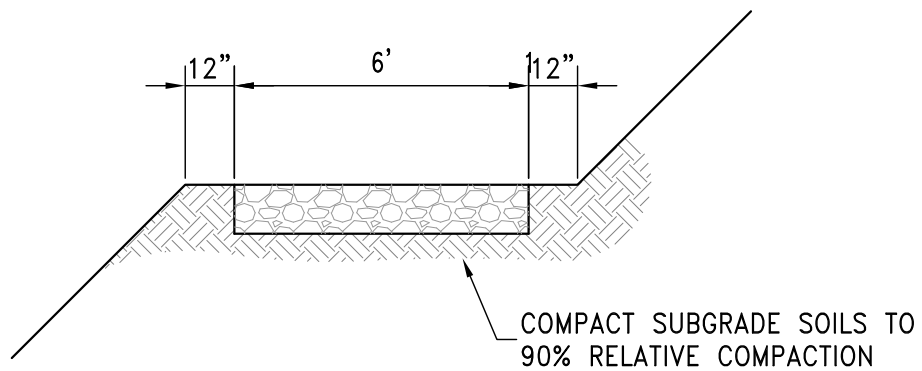

ACCESS TO SD INLETS SMALLER THAN 24" DIA. & ALL OUTLETS

NOTES:

1. 12' WIDE 6"-8" Ø COBBLE STONE LAID TO BE A "DRIVEABLE" SURFACE TO THE SATISFACTION OF THE CITY WITH HAMMERHEAD VEHICLE TURNAROUNDS.
2. 6' WIDE 6"-8" Ø COBBLE STONE LAID TO BE A "DRIVEABLE" SURFACE TO THE SATISFACTION OF THE CITY.

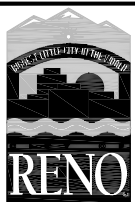

STANDARD DETAILS FOR PUBLIC WORKS CONSTRUCTION

DRAWING No.

**STORM DRAIN ACCESS ROADS
(FOR HILLSIDE DEVELOPMENT)**

R-227

APPROVED BY: JF | DATE: 1/2013