

(3) GRAVEL BAGS MIN.  
TYPE 4R CATCH BASIN.

TYPE 4R CATCH BASIN

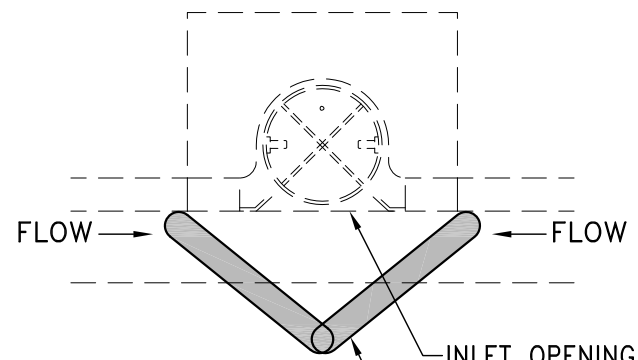

(2) GRAVEL BAGS,  
MIN. TYPE 1 CATCH  
BASIN.

TYPE 1 CATCH BASIN

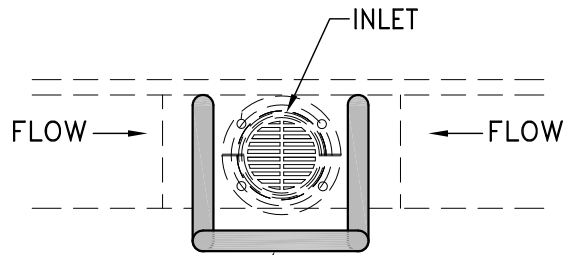

(3) GRAVEL BAGS MIN.  
INLET TYPE CATCH  
BASIN.

INLET TYPE CATCH BASIN

NOTES:

1. ALL STORM DRAIN INLET PROTECTION SHALL BE IN PLACE PRIOR TO COMMENCING CONSTRUCTION. ALL SITE BMP PLACEMENT AND MAINTENANCE SHALL CONFORM TO THE REQUIREMENTS OF THE CONTRACTOR'S STORM WATER POLLUTION PREVENTION PLAN (SWPPP).
2. THE CONTRACTOR SHALL INSPECT THE SITE DAILY, PRIOR TO FORECASTED WEATHER EVENTS AND WITHIN 24 HOURS OF ANY EVENT THAT CREATES RUNOFF AT THE SITE. DISTURBED OR BROKEN BAGS SHALL BE REPLACED. SEDIMENT AND DEBRIS SHALL BE REMOVED AND DISPOSED.
3. GRAVEL BAGS:
  - 3.1. BAGS SHALL BE WOVEN POLYPROPYLENE, POLYETHYLENE OR POLYAMITE FABRIC, MIN. WEIGHT 4oz/SY, MULLEN BURST STRENGTH EXCEEDING 300 PSI AND ULTRA VIOLET STABILITY EXCEEDING 70%.
  - 3.2. EACH GRAVEL-FILLED BAG SHALL HAVE A MIN. LENGTH OF 30", MIN. WIDTH OF 8" AND MIN. THICKNESS OF 4".
  - 3.3. GRAVEL SHALL BE BETWEEN 1/2" TO 1" IN DIAMETER AND CLEAN AND FREE FROM CLAY BALLS, ORGANIC MATTER AND OTHER DELETERIOUS MATERIALS.
4. AFTER CONSTRUCTION WHEN GRAVEL BAGS ARE REMOVED, ALL CONSTRUCTION MATERIAL, DEBRIS, SEDIMENT, ETC. SHALL BE REMOVED FROM INLET OR CATCH BASIN BY VACUUM TRUCK.



STANDARD DETAILS FOR PUBLIC WORKS CONSTRUCTION

DRAWING No.

**STORM DRAIN INLET  
PROTECTION**

**R-113**

APPROVED BY: JF

DATE: 1/2013